

6W

- 
- 
- 
- 
- 
- 
- 
- 
- 
- 

- 
- 
- 
- 
- 

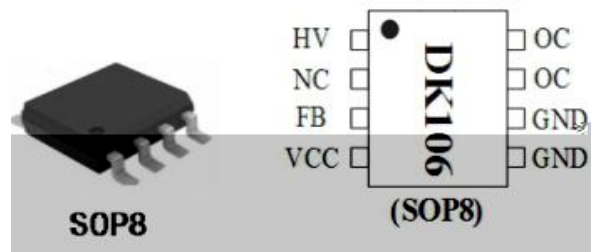

DK106			

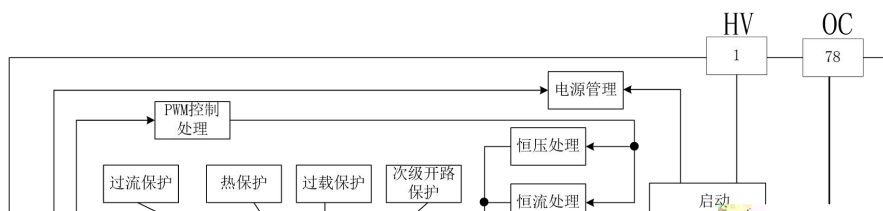
	<i>T</i>				



1.

2.

3 PWM

4 FB

5.

6.

7.

8.

9.

10.

11.

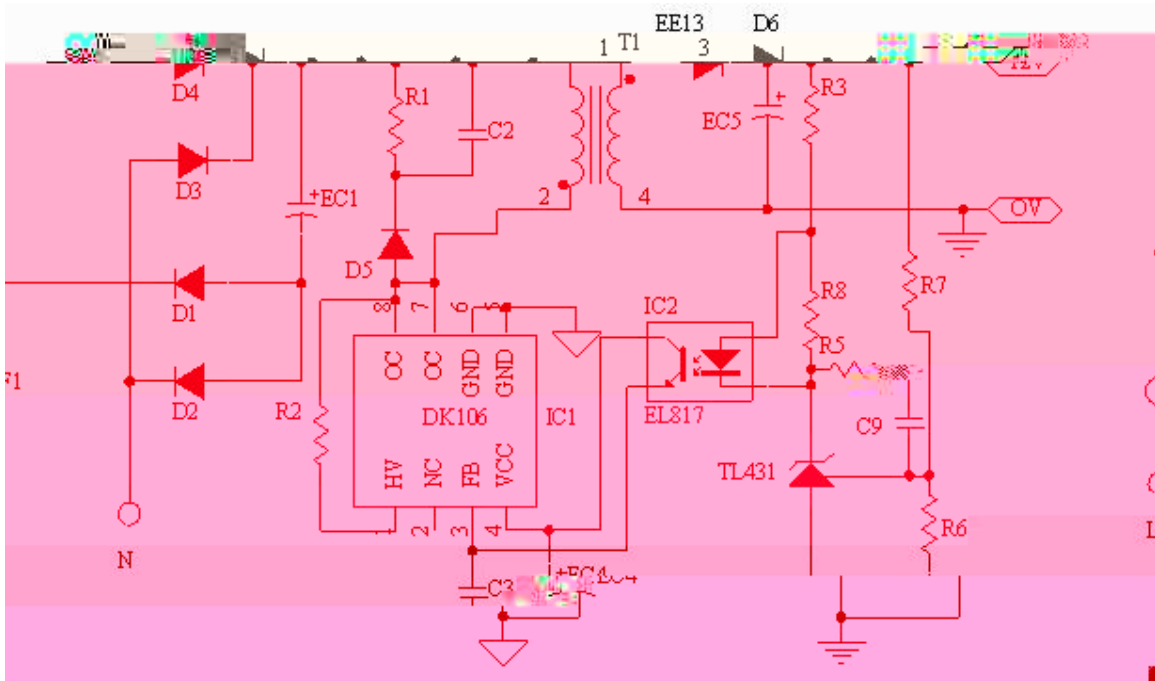





- ▼
- ▼
- ▼
- ▼
- ▼
- ▼
- ▼
  
- ▼